

NEOVOLTA™

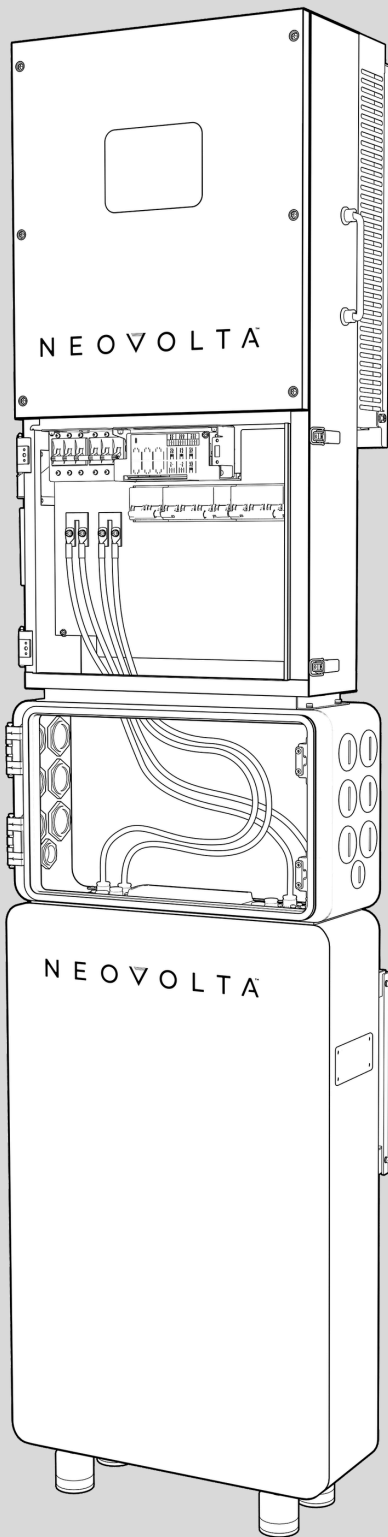

Hybrid Inverter & 16kWh Battery

NV16KAC & NVPLUS-16

Quick Installation Manual



800.364.5464

NEOVOLTA.COM

I. Pre-Installation Preparation

Safety Warnings

- Installation must be performed by qualified personnel. Read all relevant manuals before starting.
- Ensure power is OFF before installation. Disconnect batteries, PV modules, and AC power.
- Avoid battery short circuits. Verify polarity when connecting batteries.
- Comply with local electrical codes for safe and legal installation.

Required Tools & Equipment

- NVPlus-16 Battery
- NV16KAC Hybrid Inverter
- Power Cable: 2/0 AWG, 2*Positive, 2*Negative
- Screwdrivers, Wrenches, Spirit Level, Dolly, and other tools

II. Installation Steps

STEP 1: Installing the NVPlus-16 Battery

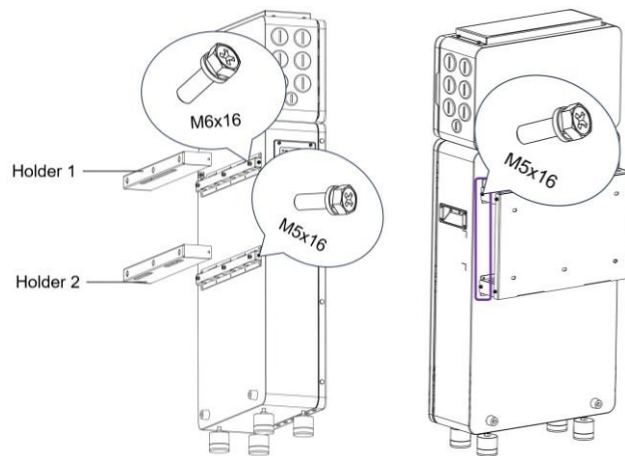
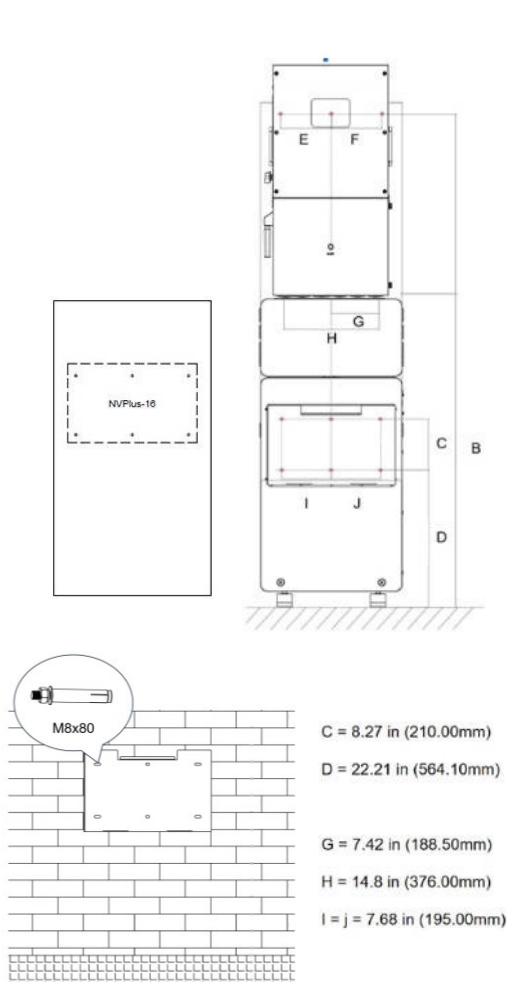

1. Prepare the Installation

- Ensure the following conditions before installation:
- Choose a suitable location: Ensure good ventilation and avoid direct sunlight or high-temperature environments.
- Pre-drill the holes: The positioning cardboard is used to assist installation, and perform precise measurements according to the dimension drawing.
- Secure the mounting panel and install leveling feet before battery installation.

2. Installation Method

- Wall-mounted installation
- Floor installation

Note: The leveling feet are not required for wall-mounted installation.

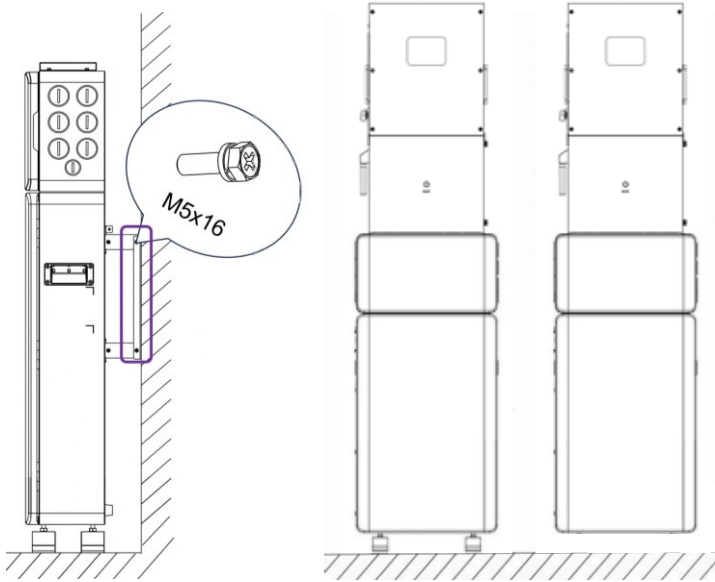

3. Battery Installation

Attach holder 1 and holder 2.

Note: When installing the holder, only the inner screws need to be mounted.

Mounting panel: Install the battery to the mounting panel and secure the external screws.

4. Junction Box

Remove the junction box cover to access inverter connection.

5. Inverter Installation

Mount the inverter directly to the pre-drilled holes to ensure a secure installation.

6. Check

- If any mounting hole misalignment exists, by adjusting the leveling feet to complete the accurate installation. **Note:** The leveling feet can support the battery and be adjusted upward by 0.2 inch (5mm).
- **Check and tighten all screws** to ensure a stable and secure installation.

STEP 2: Connect with the NV16KAC Inverter (Single Stack)

— Positive power cable
 — Communication cable
 — Ground cable
 — Negative power cable

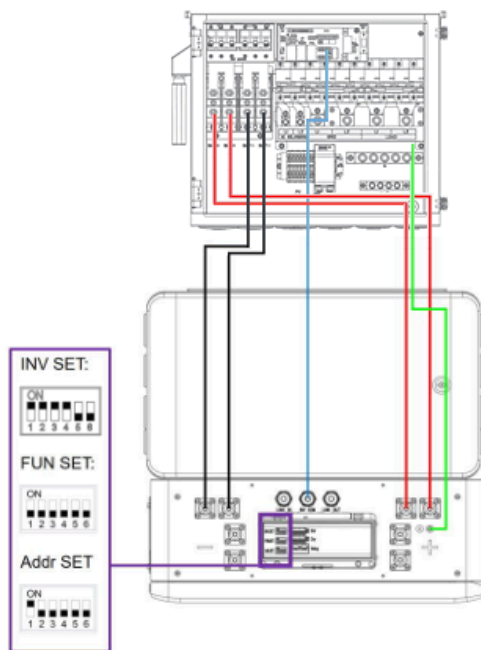

1. Power Cable Connection

- **Ensure the NV16KAC inverter and battery breaker are OFF** before making any connections.
- **Positive (+) terminal & Negative (-) terminal:** Terminal type: **2/0 AWG**
- **Ensure all terminals are securely tightened and properly insulated to prevent short circuits.**

2. Communication Cable Connection & DIP Switch Setting

- **Use RJ45 communication cables** to connect the battery's **INV COM port** to the NVPlus-16 inverter's
- Battery CANBus (BMS) port. Verify communication status on the **NVPlus-16s LCD screen** after powering on the system.

Two batteries in parallel

Power Cable Connection

Please note that the parallel needs to connect the **LINK OUT** of the #1 to the **LINK IN** of the #2.

Note: Two batteries in parallel require two power cables for electrical connection.

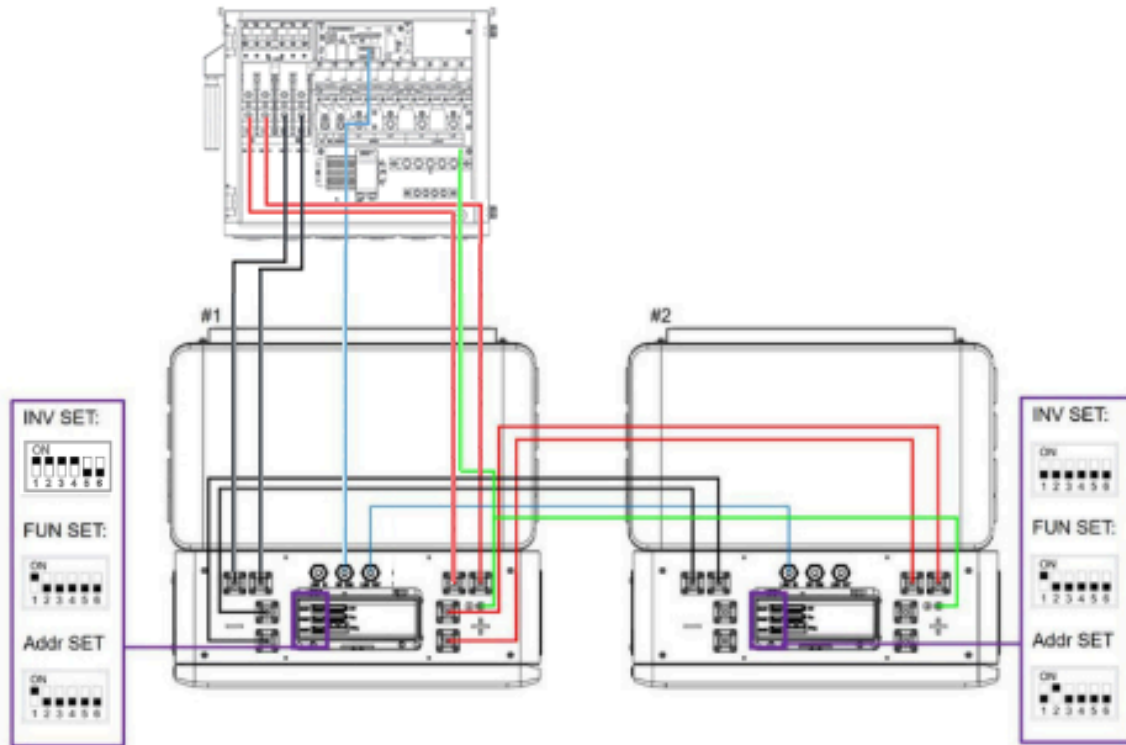

Multiple batteries in parallel

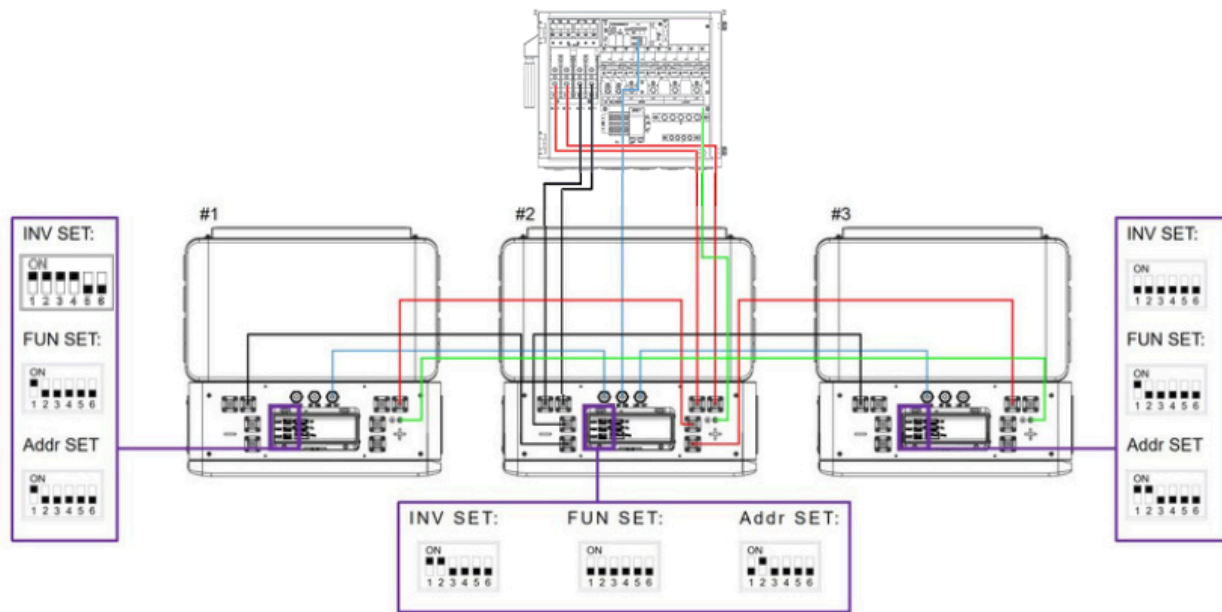

1. Dial code

- **Address:** The address dial switch is sequentially increased.
- **Inverter:** Set the inverter dial switch according to the actual usage.
- **Function:** Set the first battery and the last battery of the system's function dial code as code 1 and set function dial code of the rest of batteries as code 0.

2. Parallel Cable Connection

- Please note that the parallel needs to connect LINK OUT of the #1 to LINK IN of the #2, and the connect LINK OUT of the #2 to LINK In of the #3.

STEP 3: System Power-Up & Configuration

1. Configure Inverter Battery Settings

Close the DC switch on the NV16KAC inverter, then press the power button on the NVPlus-16 main control module to activate the system.

Set Battery Capacity:

Formula: Battery Capacity (Ah) = Battery count × 314Ah

Enable Battery Communication:

- Check "Use Batt % charged"
- Check "BMS Lithium Batt"

Set BMS Lithium Batt to "00" (this ensures proper CANBus communication with the NVPlus-16 battery)

- Check "Activate Battery"

Verify Communication:

- Ensure the **RJ45 CANBus communication cable** is securely connected between the battery and inverter.
- Confirm the **battery dial switch is set to position 1.1.1.1.0.0** (NeoVolta mode).
- Check the **LCD screen** on the NV16KAC to verify that the battery SOC (State of Charge) is displayed correctly.

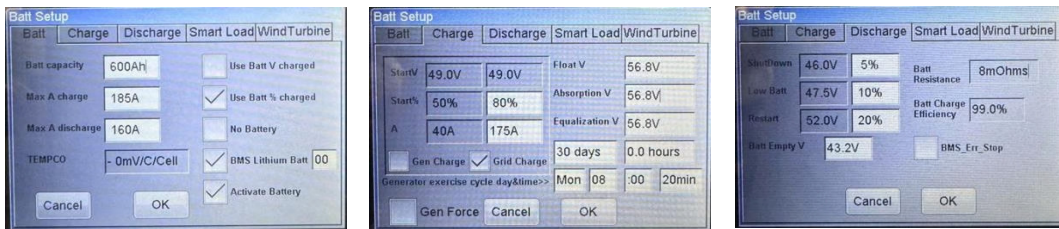

2. Battery Network Connection & Remote Monitoring

For remote monitoring and system management, follow these steps:

• Install and Register on Renon Smart App

- Download the **Renon Smart** app from **Google Play Store** or **Apple App Store**.
- Open the app, select your country, and **create an account**.

• Bind the Battery to the App

- To bind the battery to the App please contact NeoVolta Technical support at 800.364.5464 or scan the NeoVolta QR code for our support pages.

• Configure Battery Wi-Fi Connection



III. Conclusion

Following this quick guide ensures proper installation of the NVPlus-16 battery and NV16KAC Hybrid inverter for **efficient and stable system operation**. For further technical support, contact the official support team.